

ENVISIONERING PRODUCT DEVELOPMENT CLAIMS PROPRIETARY RIGHTS IN THE INFORMATION DISCLOSED HEREON. THIS DRAWING IS FURNISHED IN CONFIDENCE ON THE EXPRESS UNDERSTANDING THAT NEITHER IT NOR ANY REPRODUCTION THEREOF WILL BE DISCLOSED TO OTHERS OR USED FOR THE PURPOSE OF MANUFACTURE OR PROCUREMENT OF THE ARTICLE OR PART SHOWN HEREON.

Cylindrical Fit Reference Only

| Class | Range Min | Range Max | Pin OD | OD Plus | OD Minus | Max Pin | Min Pin | Hole ID | ID Plus | ID Minus | Max Hole | Min Hole |
|-------|-----------|-----------|---------|---------|----------|---------|---------|---------|---------|----------|----------|----------|
| RC4 | 0.00080 | 0.00280 | 0.79480 | 0.00100 | 0.00000 | 0.79580 | 0.79480 | 0.79660 | 0.00100 | 0.00000 | 0.79760 | 0.79660 |
| FN4 | -0.00040 | -0.00120 | 0.12500 | 0.00000 | 0.00040 | 0.12500 | 0.12460 | 0.12380 | 0.00040 | 0.00000 | 0.12420 | 0.12380 |

| REV | DESCRIPTION | DATE | APPROVED |
|-----|---------------------------------|---------|----------|
| A | Longer to cover balance weights | 1/15/02 | BM |
| B | Changed to taper design on end | 8/23/02 | TJM |

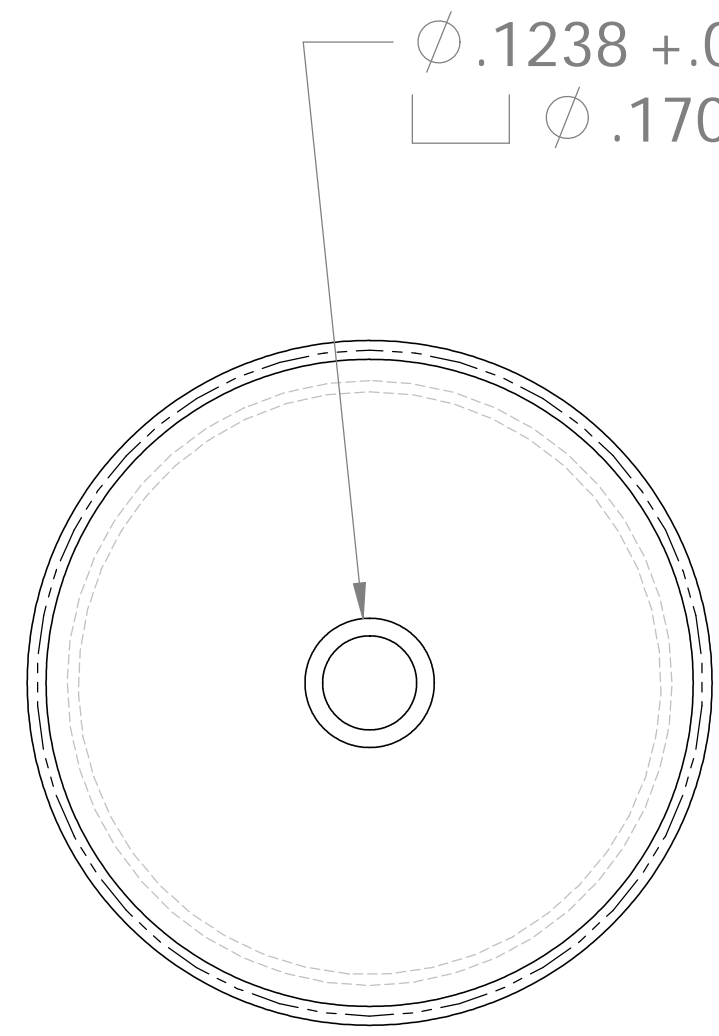

$\phi .1238 +.0004 -.0000$ Thru $\phi .1238 \nabla .1979$
 $\phi .1700 \nabla .0656$

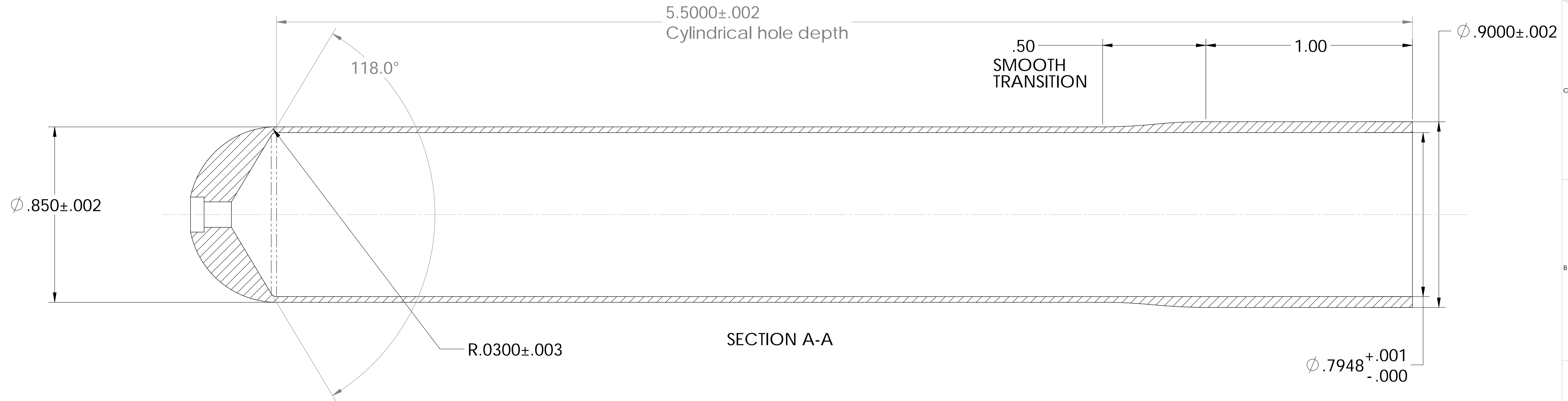
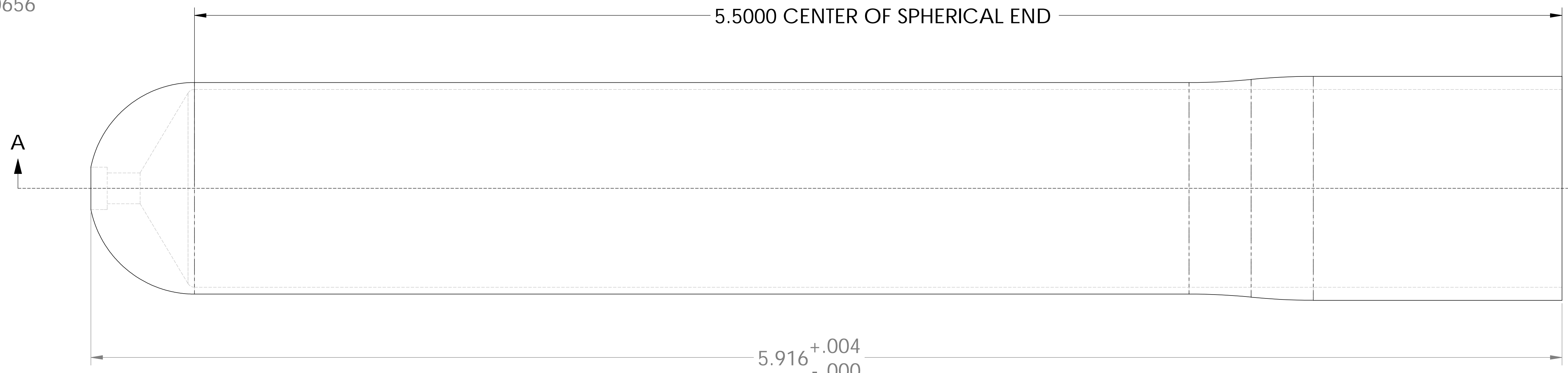

$\phi .7948 +.001 -.000$

| | | | | | |
|---|----------------------|--|------|---------------------------------|--|
| UNLESS OTHERWISE SPECIFIED DIMENSIONS ARE IN INCHES TOLERANCES ARE: | | CAD GENERATED DRAWING. DO NOT MANUALLY UPDATE. | | PARTS LIST | |
| .XX | = ± 0.015 | APPROVALS | DATE | Product Development Corporation | |
| .XXX | = ± 0.005 | DRAWN | | Tip Cover | |
| X" | = ± 0.3" | CHECKED | | SITE DWG. NO. B02T112085 | |
| FINISH | | RESP'G | | REV D | |
| NEXT ASSY | USED ON | MFG'G | | SCALE: 1:1 | |
| APPLICATION | DO NOT SCALE DRAWING | QUAL'G | | SHEET 1 OF 1 | |

Cylindrical Fit Reference Only

| Class | Range | Min | Range | Max | Pin OD | OD Plus | OD Minus | Max Pin | Min Pin | Hole ID | ID Plus | ID Minus | Max Hole | Min Hole |
|-------|----------|----------|---------|---------|---------|---------|----------|---------|---------|----------|---------|----------|----------|----------|
| RC4 | 0.00040 | 0.00160 | 0.12500 | 0.00000 | 0.00050 | 0.12500 | 0.12450 | 0.12540 | 0.00070 | 0.00000 | 0.12610 | 0.12540 | | |
| LCS | 0.00000 | 0.00100 | 0.06250 | 0.00000 | 0.00020 | 0.06250 | 0.06240 | 0.06260 | 0.00080 | 0.00000 | 0.06340 | 0.06260 | | |
| RC3 | 0.00030 | 0.00090 | 0.09380 | 0.00000 | 0.00020 | 0.09380 | 0.09360 | 0.09410 | 0.00045 | 0.00000 | 0.09455 | 0.09410 | | |
| FNS | -0.00060 | -0.00160 | 0.31250 | 0.00000 | 0.00020 | 0.31250 | 0.31230 | 0.31090 | 0.00080 | 0.00000 | 0.31170 | 0.31090 | | |
| LC1 | 0.00000 | 0.00045 | 0.09380 | 0.00000 | 0.00020 | 0.09380 | 0.09360 | 0.09390 | 0.00045 | -0.00020 | 0.09405 | 0.09390 | | |
| FN1 | -0.00010 | -0.00075 | 0.37500 | 0.00000 | 0.00020 | 0.37500 | 0.37480 | 0.37425 | 0.00045 | 0.00000 | 0.37470 | 0.37425 | | |
| FNS | -0.00030 | -0.00130 | 0.09400 | 0.00010 | 0.00010 | 0.09410 | 0.09390 | 0.09280 | 0.00080 | 0.00000 | 0.09360 | 0.09280 | | |

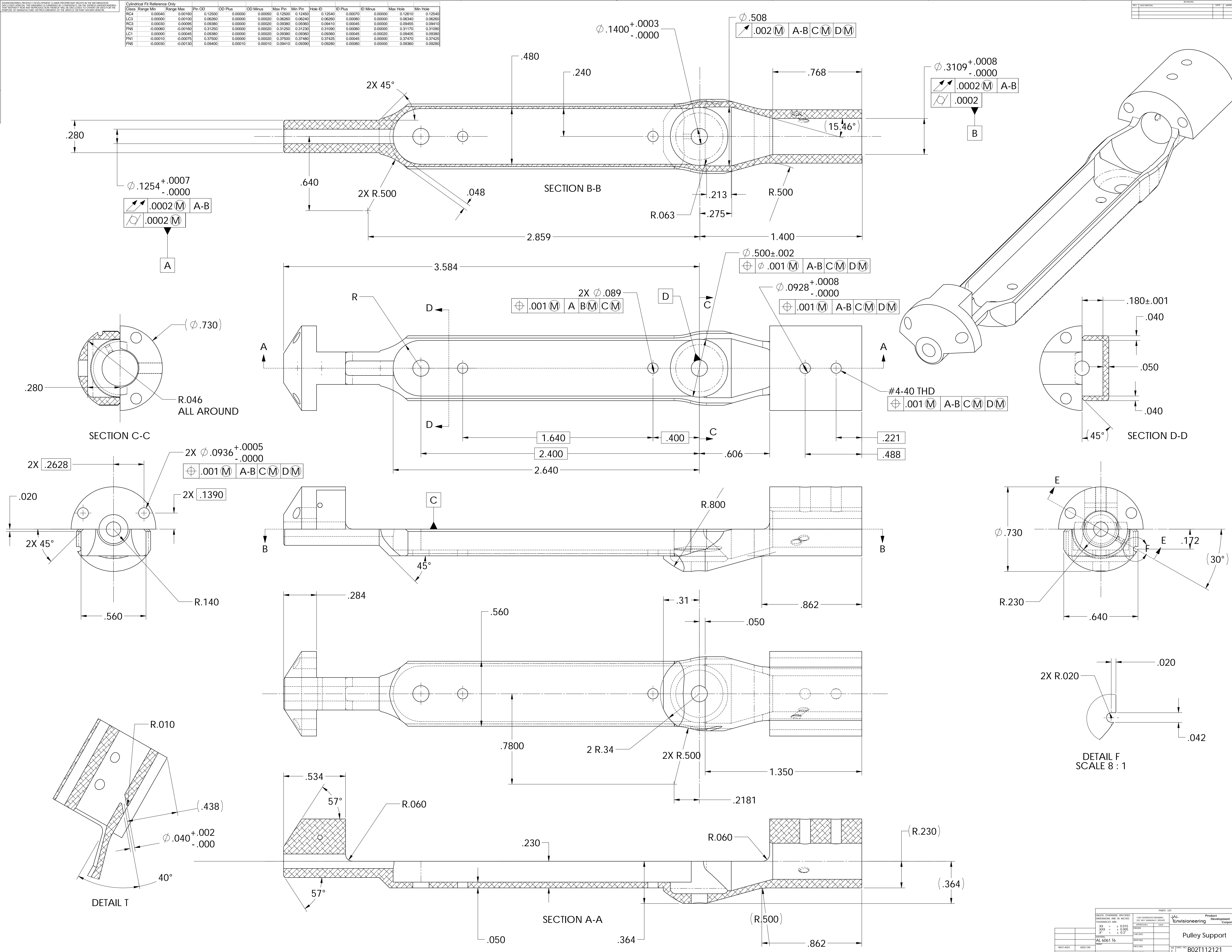

PARTS LIST

| ITEM NO | DESCRIPTION | QTY | UNIT | SCALE |
|---------|----------------|-----|------|-------|
| 1 | Pulley Support | 1 | PC | 8:1 |

Product Development Corporation
 B021112121
 SCALE: 8:1

UNLESS OTHERWISE SPECIFIED, DIMENSIONS ARE TO BE TAKEN TO THE CENTERLINE OF THE PART UNLESS OTHERWISE SPECIFIED. DIMENSIONS ARE TO BE TAKEN TO THE CENTERLINE OF THE PART UNLESS OTHERWISE SPECIFIED.

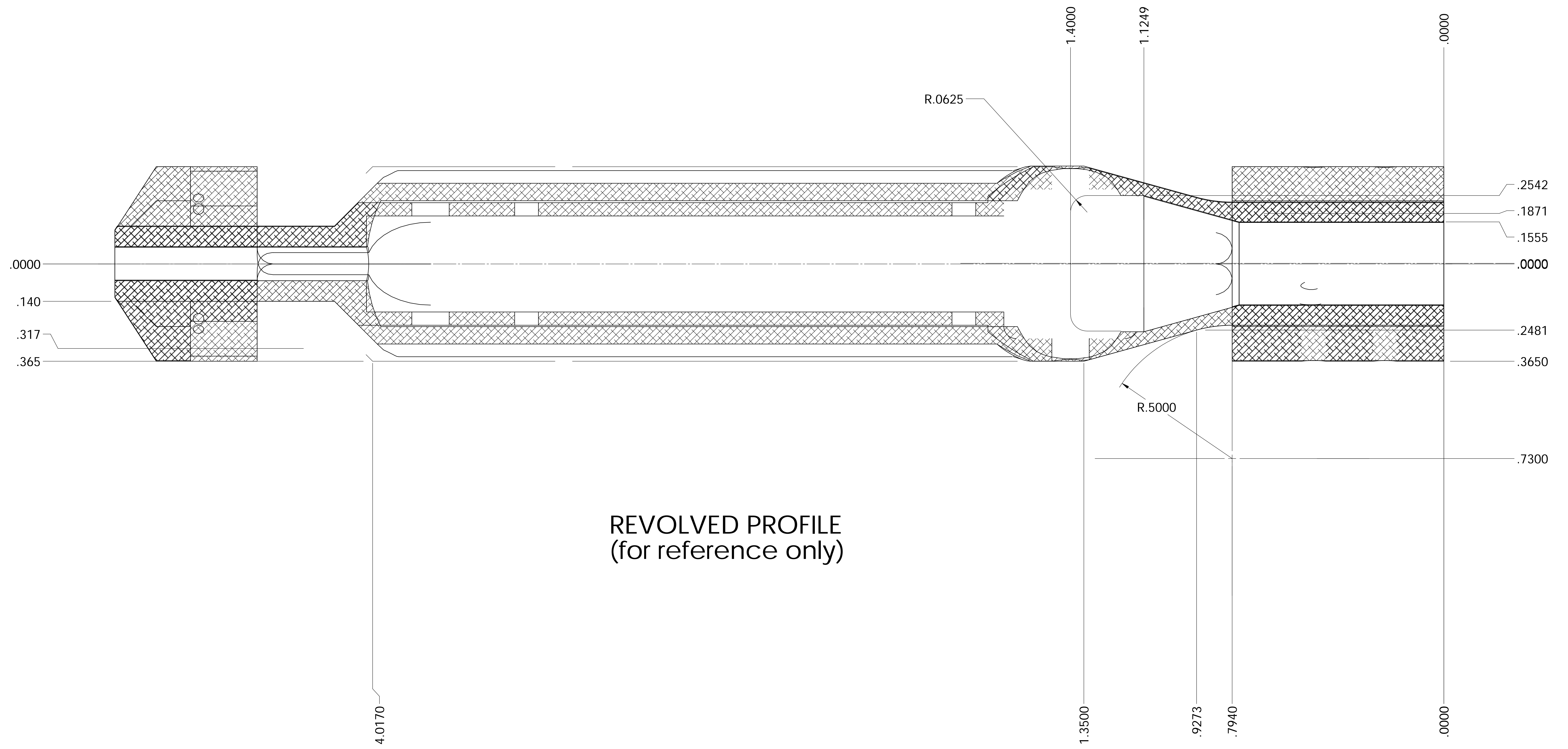

REVOLVED PROFILE
(for reference only)

ENVISIONEERING PRODUCT DEVELOPMENT CLAIMS PROPRIETARY RIGHTS IN THE INFORMATION DISCLOSED HEREON. THIS DRAWING IS FURNISHED IN CONFIDENCE ON THE EXPRESS UNDERSTANDING THAT NEITHER IT NOR ANY REPRODUCTION THEREOF WILL BE DISCLOSED TO OTHERS OR USED FOR THE PURPOSE OF MANUFACTURE OR PROCUREMENT OF THE ARTICLE OR PART SHOWN HEREON.

| Class | Range Min | Range Max | Pin OD | OD Plus | OD Minus | Max Pin | Min Pin | Hole ID | ID Plus | ID Minus | Max Hole | Min Hole |
|-------|-----------|-----------|---------|---------|----------|---------|---------|---------|---------|----------|----------|----------|
| RC1 | 0.00010 | 0.00045 | 0.14060 | 0.00000 | 0.00020 | 0.14060 | 0.14040 | 0.14070 | 0.00015 | 0.00000 | 0.14085 | 0.14070 |

| REVISIONS | | DATE | APPROVED |
|-----------|-------------|------|----------|
| REV. | DESCRIPTION | | |
| | | | |

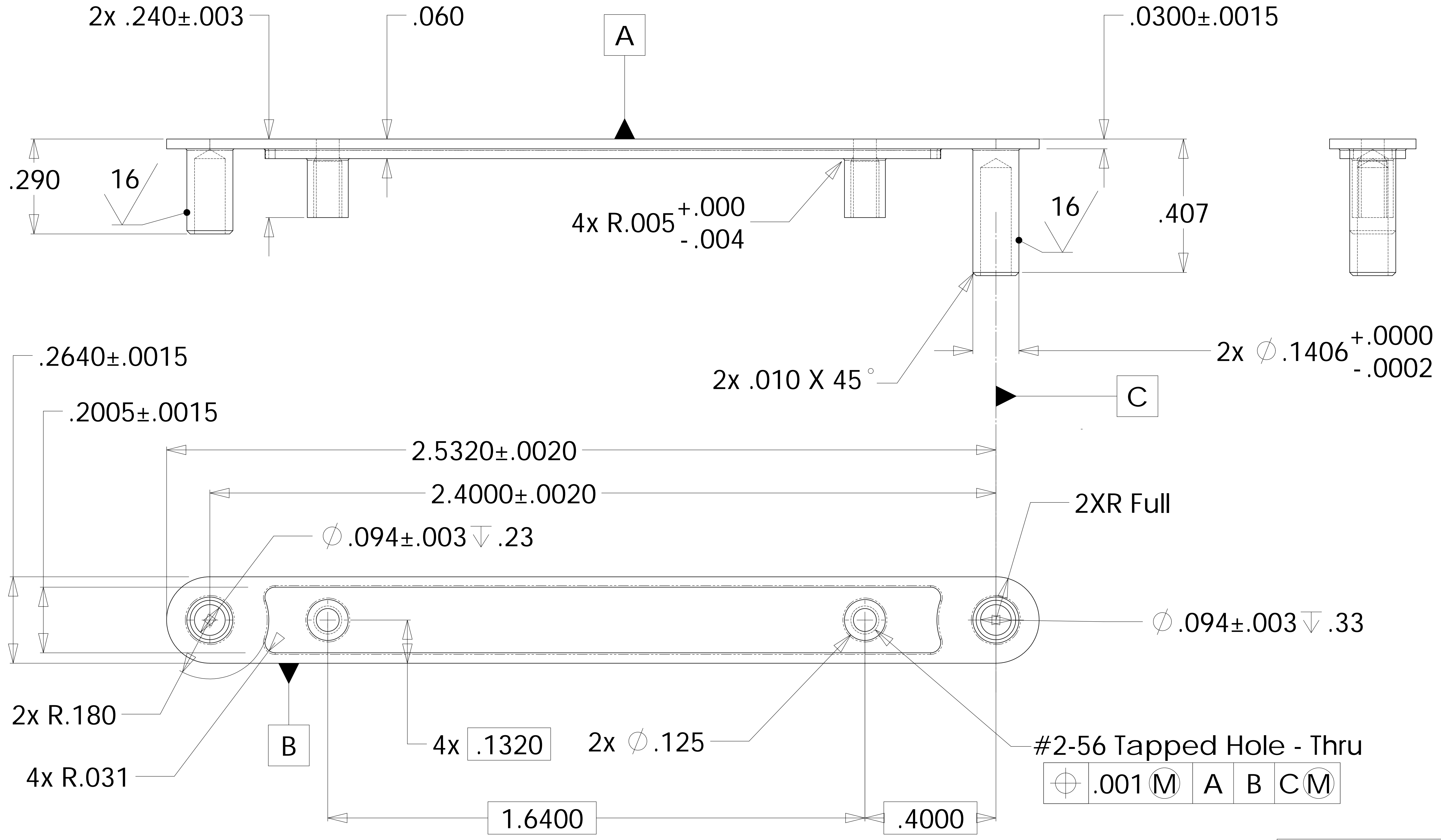
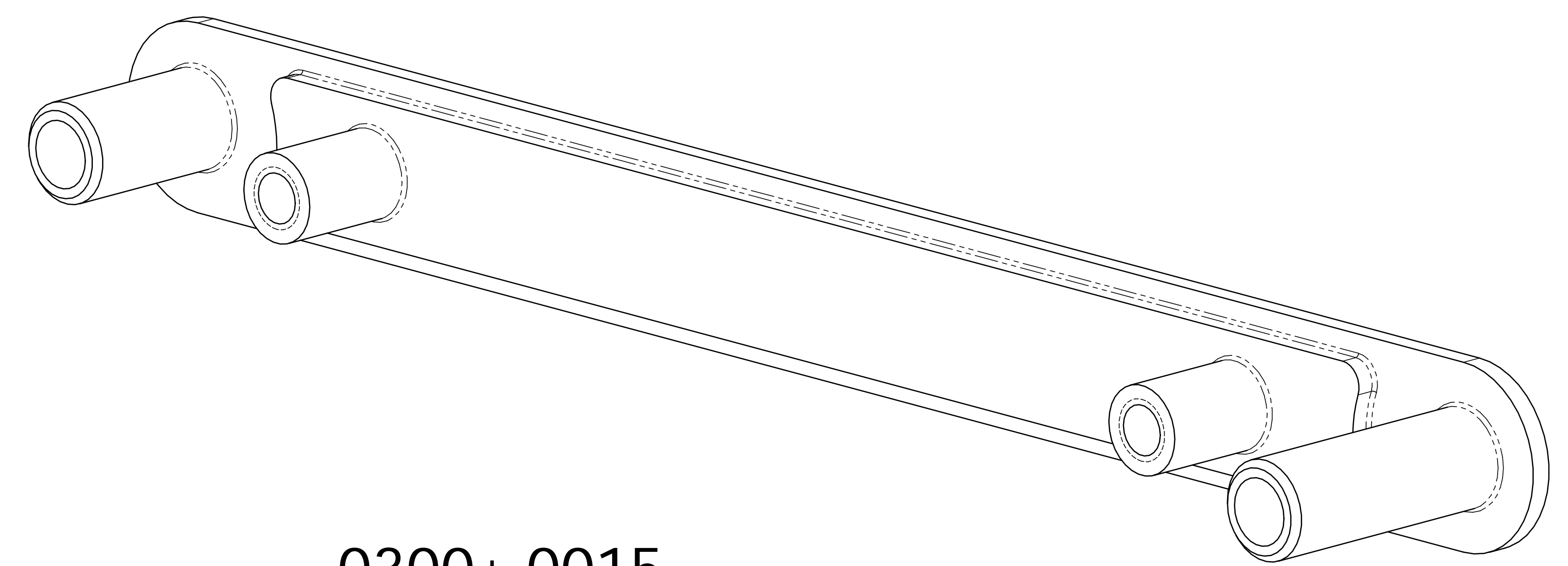

| PARTS LIST | | Product Development Corporation | |
|---|----------------|---|--------------|
| UNLESS OTHERWISE SPECIFIED DIMENSIONS ARE IN INCHES TOLERANCES ARE: | | CAD GENERATED DRAWING. DO NOT MANUALLY UPDATE | |
| .XX = ± 0.015 | .XXX = ± 0.005 | APPROVALS | DATE |
| .X° = ± 0.3° | | DRAWN | |
| MATERIAL | SS 303 | CHECKED | |
| FINISH | | RESP ENG | |
| | | MFG ENG | |
| | | QUAL ENG | |
| DO NOT SCALE DRAWING | | Inner Track Plate | |
| NEXT ASSY | USED ON | SIZE | DWG. NO. |
| APPLICATION | | C | B02T112127 |
| | | SCALE | 4:1 |
| | | CAD FILE | B02T112127 |
| | | | SHEET 1 OF 2 |

ENVISIONEERING PRODUCT DEVELOPMENT CLAIMS PROPRIETARY RIGHTS IN THE INFORMATION DISCLOSED HEREON. THIS DRAWING IS FURNISHED IN CONFIDENCE ON THE EXPRESS UNDERSTANDING THAT NEITHER IT NOR ANY REPRODUCTION THEREOF WILL BE DISCLOSED TO OTHERS OR USED FOR THE PURPOSE OF MANUFACTURE OR PROCUREMENT OF THE ARTICLE OR PART SHOWN HEREON.

| REVISIONS | | | |
|-----------|-------------|------|----------|
| REV. | DESCRIPTION | DATE | APPROVED |
| | | | |
| | | | |
| | | | |

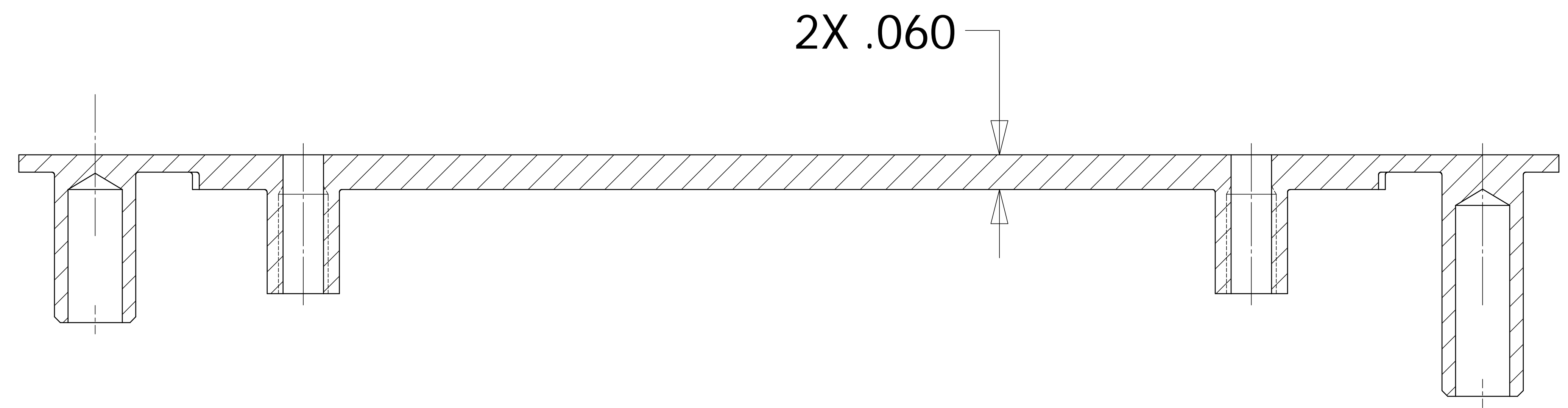

SECTION A-A

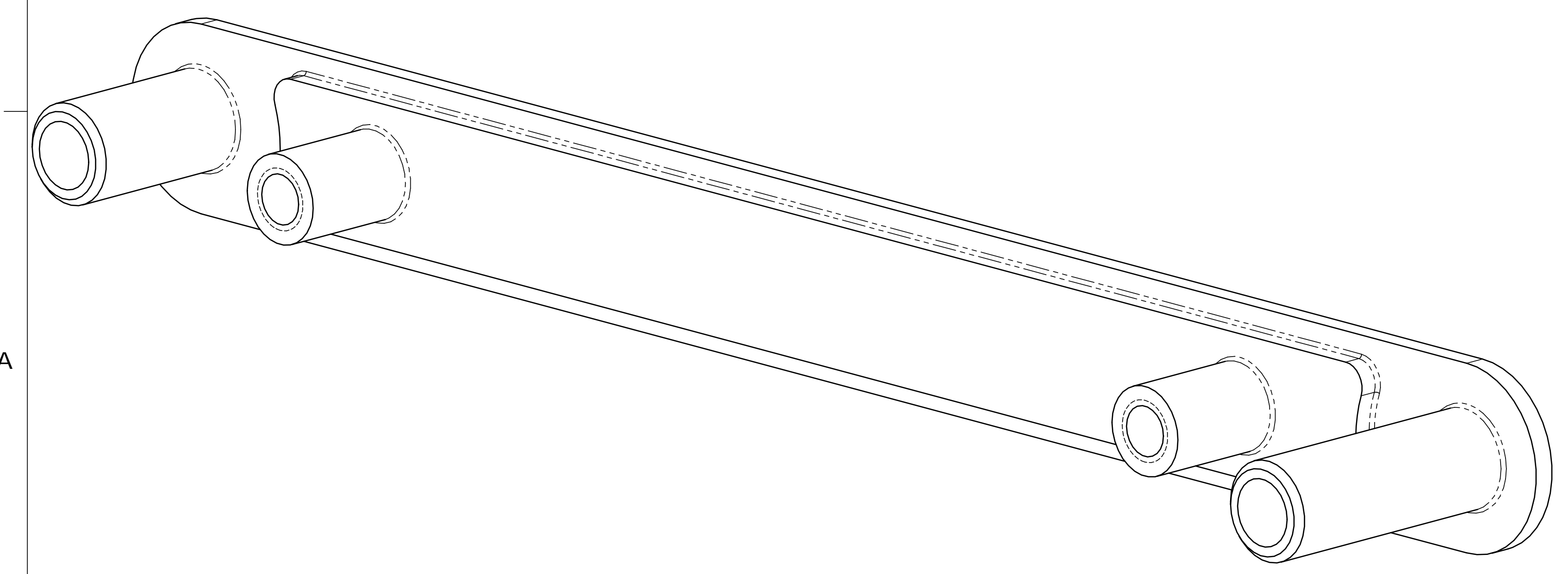
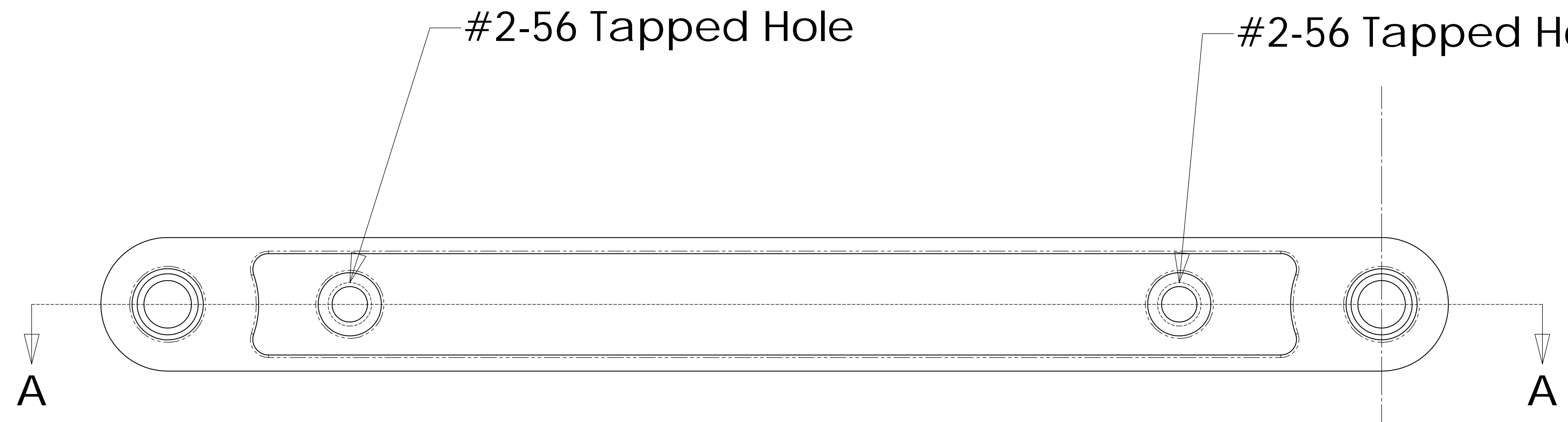

| PARTS LIST | | Product Development Corporation | |
|---|---|--|------|
| UNLESS OTHERWISE SPECIFIED DIMENSIONS ARE IN INCHES TOLERANCES ARE: | CAD GENERATED DRAWING. DO NOT MANUALLY UPDATE | APPROVALS | DATE |
| .XX = ± 0.015 | | DRAWN | |
| .XXX = ± 0.005 | | CHECKED | |
| .X° = ± 0.3° | | RESP ENG | |
| MATERIAL | SS 303 | MFG ENG | |
| FINISH | | QUAL ENG | |
| NEXT ASSY | USED ON | Inner Track Plate DWG. NO. B02T112127 SCALE 4:1 CAD FILE B02T112127 SHEET 2 OF 2 | |
| APPLICATION | DO NOT SCALE DRAWING | | |