

ENVISIONERING PRODUCT DEVELOPMENT CLAIMS PROPRIETARY RIGHTS IN THE INFORMATION DISCLOSED HEREON. THIS DRAWING IS FURNISHED IN CONFIDENCE, ON THE EXPRESS UNDERSTANDING THAT NEITHER IT NOR ANY REPRODUCTION THEREOF WILL BE DISCLOSED TO OTHERS OR USED FOR THE PURPOSE OF MANUFACTURE OR PROCUREMENT OF THE ARTICLE OR PART SHOWN HEREON.

REV.	DESCRIPTION	DATE	APPROVED

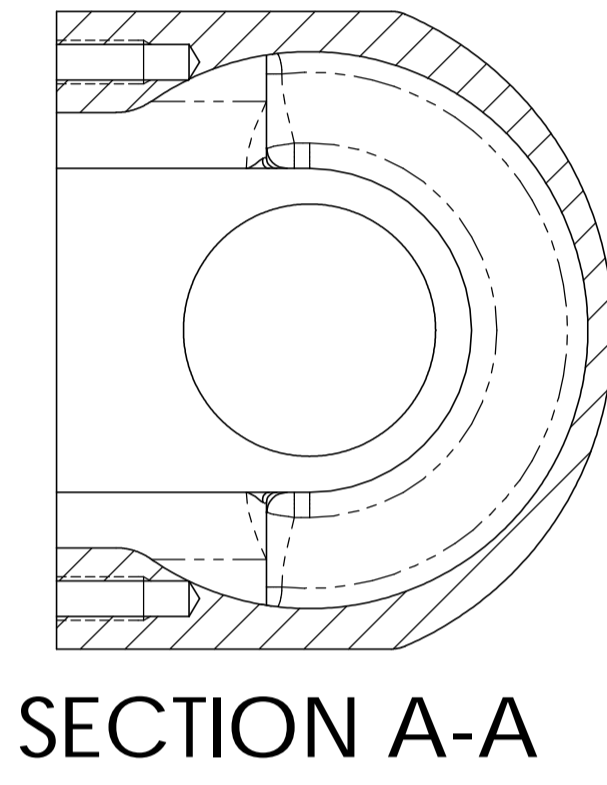

SECTION A-A

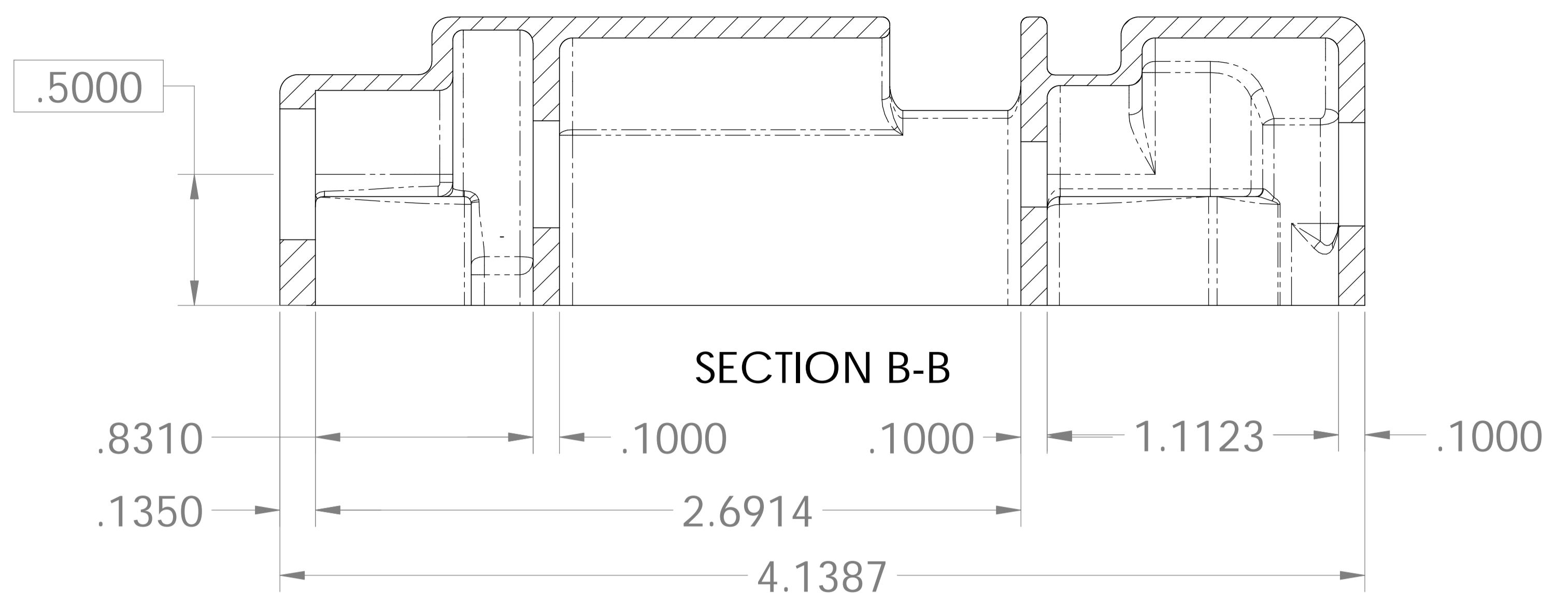
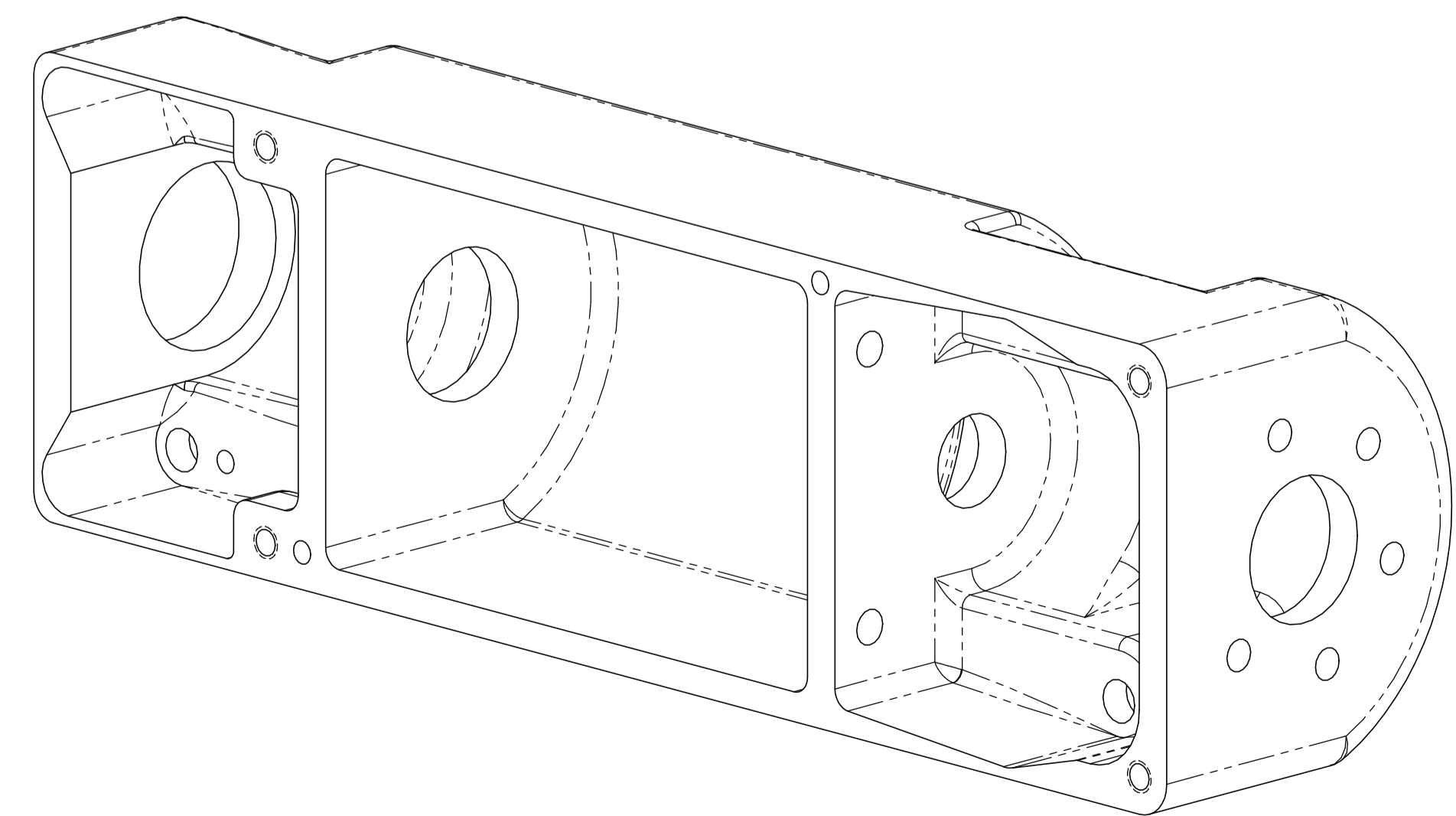
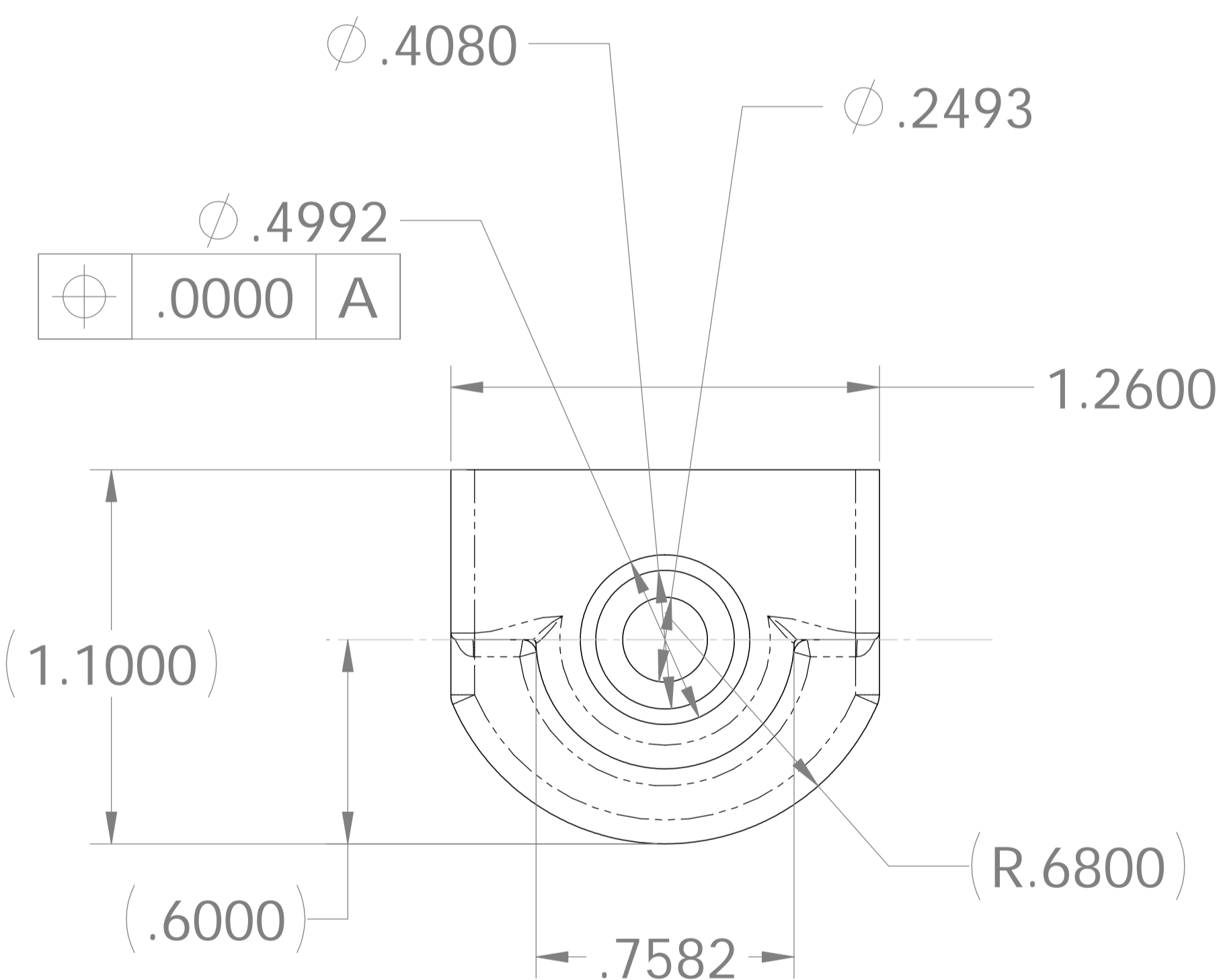

SECTION B-B

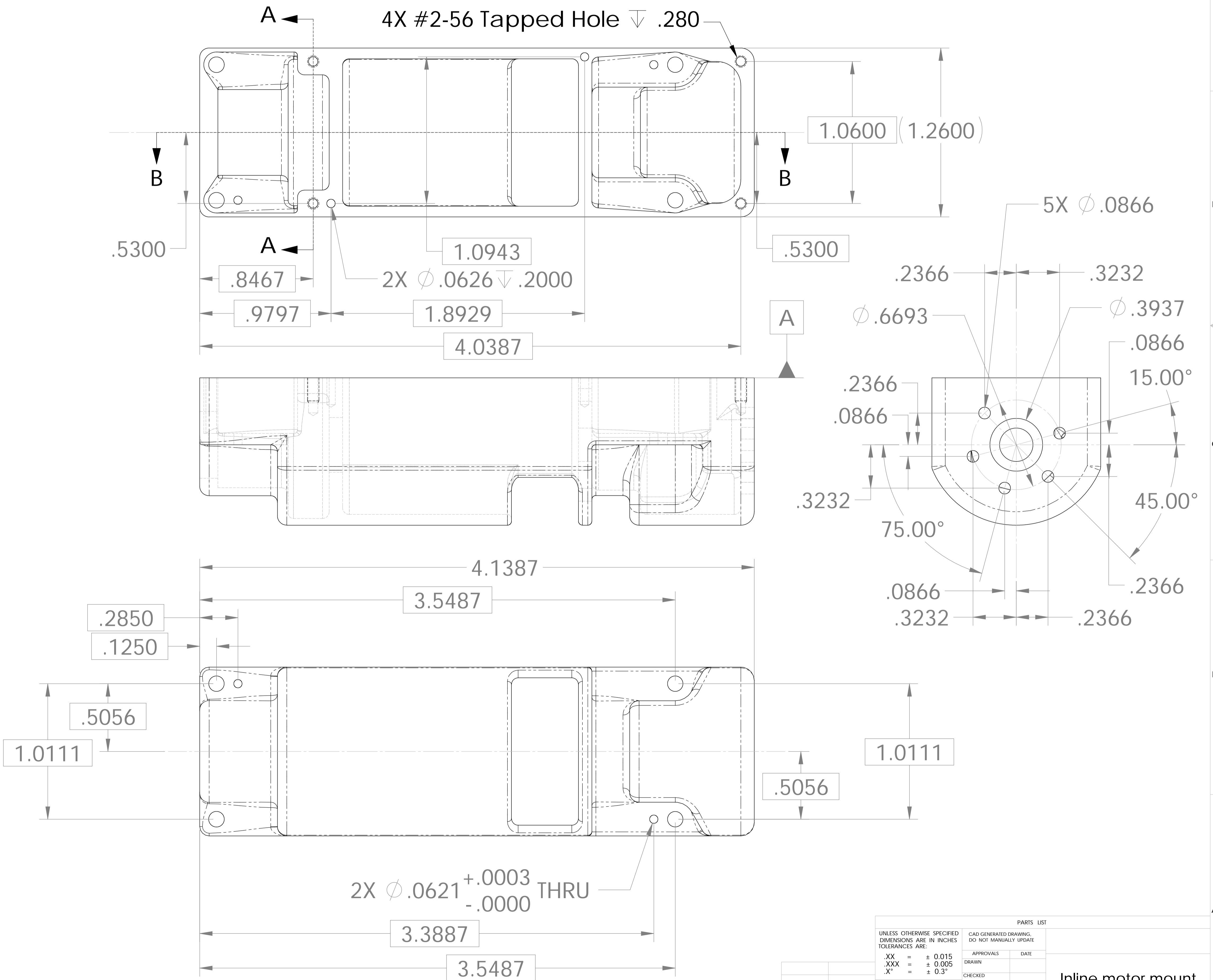

UNLESS OTHERWISE SPECIFIED DIMENSIONS ARE IN INCHES TOLERANCES ARE:		CAD GENERATED DRAWING. DO NOT MANUALLY UPDATE.		PARTS LIST	
XX	= ± 0.015	APPROVALS	DATE		
XXX	= ± 0.005	DRAWN			
X"	= ± 0.3"	CHECKED			
MATERIAL:		RESP'NG			
AI		MFG'ENG			
FINISH		QUAL'ENG			
NEXT ASSY	USED ON	SCALE		SHEET	
APPLICATION	DO NOT SCALE DRAWING	SCALE 2:1		1	

Response Mechanics  
 Ranny Meier  
 Ranny@RespMech.com  
 636-532-1003

Inline motor mount

B02T122215

SHEET 1 OF 1